

DRG No.

IF IN DOUBT ASK

ALL DIMENSIONS IN MILLIMETRES UNLESS STATED

DO NOT SCALE

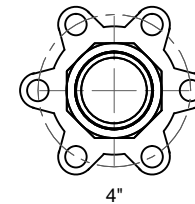
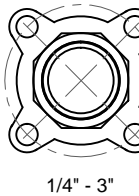
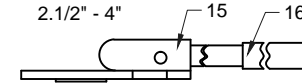
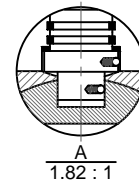
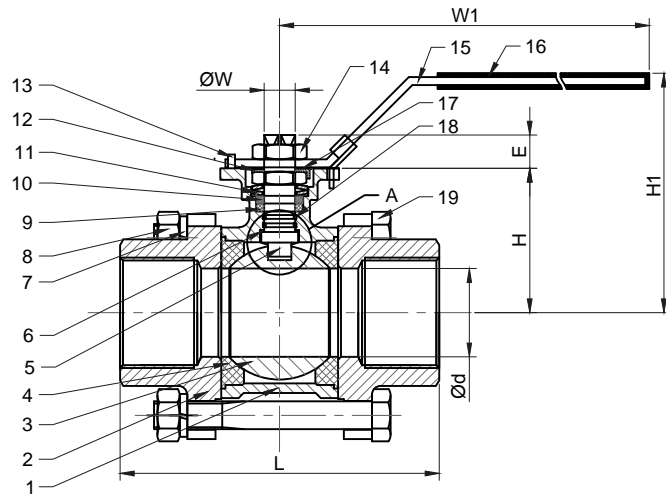
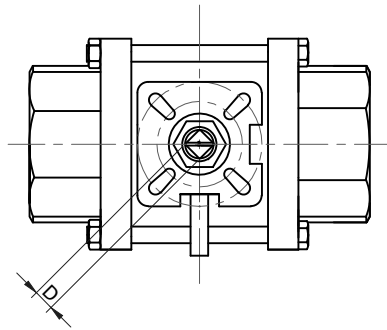

- FEATURES:
- DIMENSIONS: 1/4" TO 2" TO DIN-3202-M3
 - BODY THICKNESS TO EN12516-3
 - PIPE THREAD IN ACCORDANCE: NPT, BSPT, DIN259, DIN2999, ISO228 CLASS A
 - FACE TO FACE: DIN-3202-M3
 - BLOW-OUT PROOF STEM/FULL PORT
 - WITH ISO 5211 MOUNTING PAD
 - INVESTMENT CASTING BODY
 - 1000PSI (PN63) W.O.G.
 - WITH LOCKING DEVICE
 - MATERIAL: SS316/ASTM A351Gr-CF8M/DIN1.4408

SIZE	Ød±0.5	Ød1±0.5	L±2	L1±2	H±1	D ^{+0.00} / _{-0.07}	E±1	ØW ^{+0.0} / _{-0.3}	ISO 5211	Break-out Torque	W1	H1
1/4"	11.5	14.2	55	60	38	9	9	12	F03/F04	6.25Nm	143	65
3/8"	12.5	17.7	60	60	38	9	9	12	F03/F04	6.25Nm	143	65
1/2"	15	21.8	75	70	38	9	9	12	F03/F04	7.81Nm	143	65
3/4"	20	27.2	80	85	47	9	9	12	F03/F04	12.5Nm	143	76
1"	25	34	90	95	60	11	11	14	F04/F05	15.63Nm	168	95
1.1/4"	32	42.7	110	110	62.7	11	11	14	F04/F05	26.56Nm	168	95
1.1/2"	38	48.8	120	120	79	14	15	18	F05/F07	37.5Nm	190	115
2"	50	61.2	140	142	88	14	15	18	F05/F07	49.22Nm	190	124
2.1/2"	65	74	162	166	109.1	17	17	22	F07/F10	87.5Nm	350	140
3"	80	90	184	182	116.2	17	17	22	F07/F10	143.75Nm	350	150
4"	100	115.6	228	227	142	22	22	28	F10/F12	200Nm	350	175

REV	DATE	DESCRIPTION OF REVISION	SIGN

ITEM	DESCRIPTION	QTY	MANUFACTURER / REF	MATERIAL
1	BODY	1		CF8M/CF8
2	CAP	2		CF8M/CF8
3	BALL	1		CF8M/CF8
4	BALL SEAT	2		RPTFE
5	STEM	1		SS304/SS316
6	THRUST WASHER	1		PTFE
7	SPRING WASHER	4		SS304
8	BOLT NUT	4		SS304
9	STEM PACKING	1		PTFE
10	RING	1		SS304
11	BELLEVILLE WASHER	2		SS301
12	LOCK WASHER	1		SS304
13	STOP PIN	1		SS304
14	HANDLE NUT	2		SS304
15	HANDLE	1		SS304
16	HANDLE SLEEVE	1		PVC
17	WASHER	1		CF8M/CF8
18	O-RING	1		VITON
19	BOLT	4		SS304

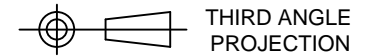

DESCRIPTION:

**EUROTORC MODEL EV 303
3-PIECE STAINLESS STEEL
FULL BORE BALL VALVE**

EUROTORC
sales@eurotorc.com
www.eurotorc.com



DRAWN SMP
DATE 02/09/15
APPROVED

THIS DRAWING IS THE PROPERTY OF EUROTORC AND MUST NOT BE COPIED, LENT OR USED IN PART OR IN WHOLE WITHOUT WRITTEN CONSENT.