

DRG No. ED0186

IF IN DOUBT ASK

ALL DIMENSIONS IN MILLIMETRES UNLESS STATED

DO NOT SCALE

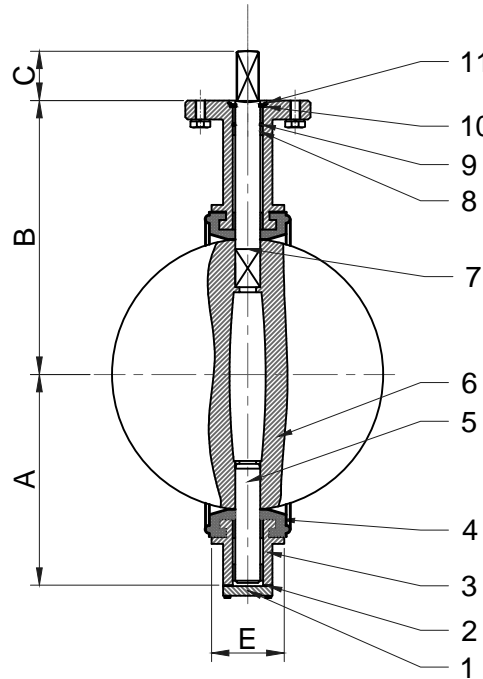
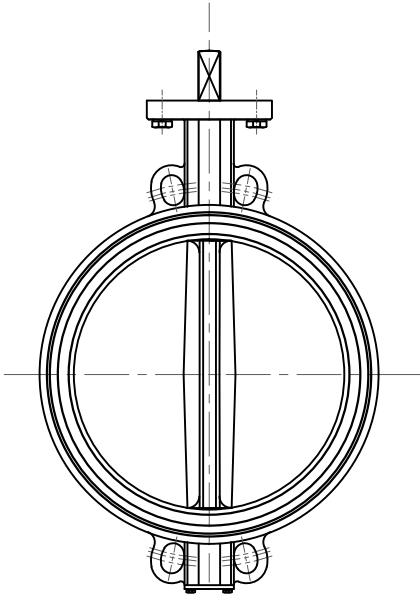
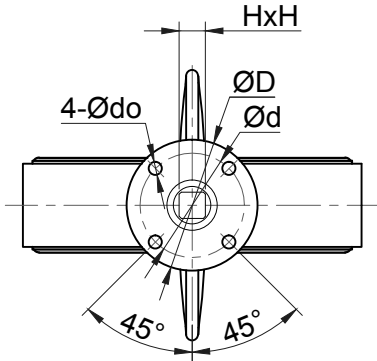

SIZE	A	B	C	E	ØD	Ød	4-Ødo	HxH	Kg
DN350	263	346	29	78	150	125	4 - 14	27x27	39.83
DN400	300	375	29	102	175	140	4 - 18	27x27	58.82
DN450	333	400	38	114	175	140	4 - 18	36x36	67.98
DN500	366	432	38	127	175	140	4 - 18	36x36	136.2
DN600	447	562	38	154	210	165	4 - 22	36x36	211.3

Face to Face Dim. According to EN558 Series 20
 ISO5752 Series 20
 BS5155 Series 4
 Top Flange According to ISO5211
 Flange Accomodation: EN1092-1 PN10/16

REV	DATE	DESCRIPTION OF REVISION	SIGN

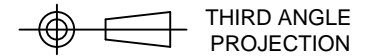

DESCRIPTION:

**EUROTORC ETW-710
 WAFER PATTERN BUTTERFLY VALVE
 DN350 TO DN600**

ITEM	DESCRIPTION	QTY
1	LOWER STEM COVER	1
2	LOWER STEM COVER SEAL	1
3	BODY	1
4	SEAT	1
5	LOWER STEM	1
6	DISC	1
7	UPPER STEM	1
8	BEARING	5
9	STEM SEAL	1
10	ANTI-EXTRUSION RING / FOLLOWER	1
11	CIRCLIP	1

EUROTORC
 sales@eurotorc.com
 www.eurotorc.com



DRAWN SMP
 DATE 16/06/15
 APPROVED

THIS DRAWING IS THE PROPERTY OF EUROTORC AND MUST NOT BE COPIED, LENT OR USED IN PART OR IN WHOLE WITHOUT WRITTEN CONSENT.